

Wey Knife Gate Valve VNA

2.4.10

DN 50–400 Standard construction

Material acc. to data sheet 2.0.13

Body and upper construction with epoxy powder coating

Stainless steel parts without coating

Flange drilling: PN 10/16 EN 1092 / ISO 7005

Face-to-face: EN 558-1/ ISO 5752 part 20

Nominal pressure PN: DN 50–200 10 bar
DN 250–300 6 bar
DN 350–400 4 bar

Operating pressure: Refer to table column OP

For dead-end installation we recommend to use steel-enforced rubber gasket

Test acc. EN 12266-1, rate A

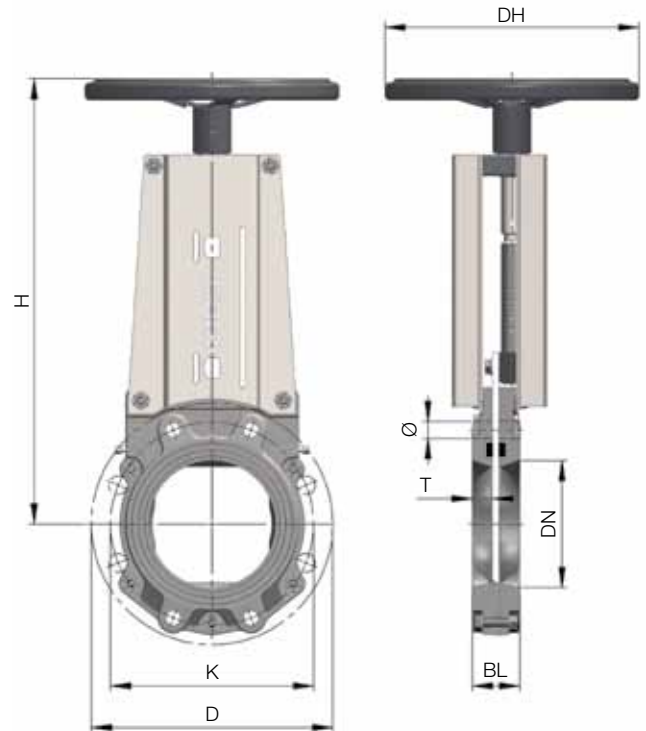

DN	D	K	BL	H	DH	Ø	T	Qty screws	⊕	⊕	OP max. bar	Weight [kg]
50	165	125	43	328	150	M16	17	4	4	–	10	7
65	185	145	46	340	150	M16	17	4	4	–	10	8
80	200	160	46	358	200	M16	17	8	4	4	10	9
100	220	180	52	411	200	M16	20	8	4	4	10	12
125	250	210	56	452	200	M16	22	8	4	4	10	14
150	285	240	56	526	300	M20	21	8	4	4	10	22
200	340	295	60	606	300	M20	23	8	4	4	10	29
250	395	350	68	696	300	M20	19	12	6	6	6	40
300	445	400	78	792	400	M20	23	12	6	6	6	65
350	505	460	78	905	400	M20	20	16	8	8	4	89
400	565	515	102	987	400	M24	28	16	6	10	4	115