

Wey Knife Gate Valve VNC

2.4.30

DN 50–400 Standard construction

Valve operated by pneumatic or hydraulic cylinder

Supply pressure 6–8 bar on cylinder

Material acc. to data sheet 2.0.13

Body and upper construction with epoxy powder coating

Stainless steel parts without coating

Flange drilling: PN 10/16 EN 1092 / ISO 7005

Face-to-face: EN 558-1 / ISO 5752 part 20

Nominal pressure PN: DN 50–200 10 bar
DN 250–300 6 bar
DN 350–400 4 bar

Operating pressure: Refer to table column OP

For dead-end installation we recommend to use steel-enforced rubber gasket

Test acc. EN 12266-1, rate A

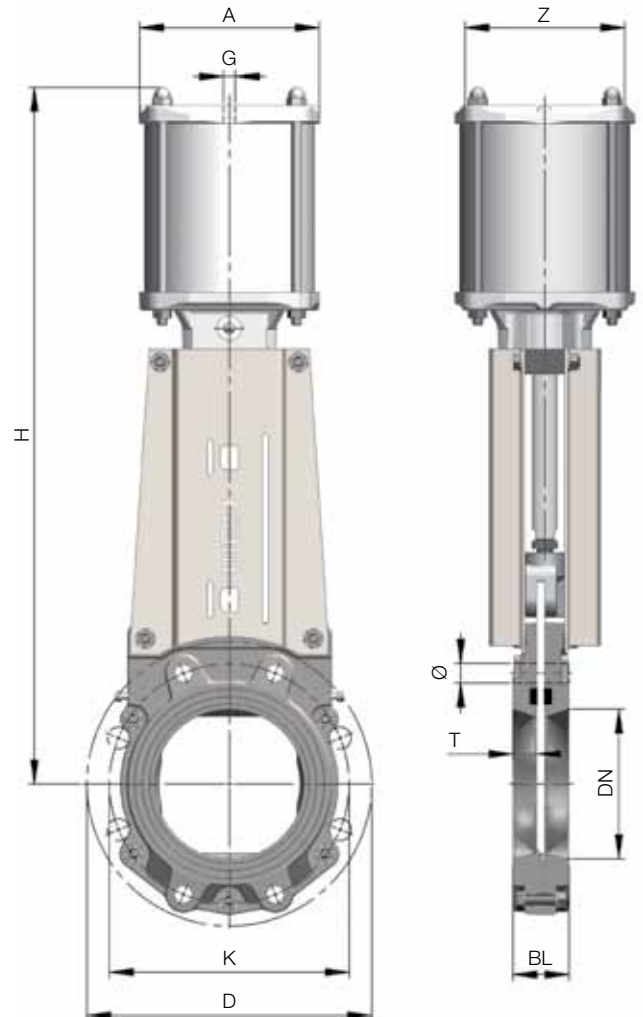

DN	D	K	BL	H	Z	A	G	Ø	T	Qty screws	⊕	⊕	*OP max. bar	Weight [kg]
50	165	125	43	407	100	140	ISO 228-G¼	M16	17	4	4	–	10	8
65	185	145	46	429	100	140	ISO 228-G¼	M16	17	4	4	–	10	9
80	200	160	46	462	100	140	ISO 228-G¼	M16	17	8	4	4	10	10
100	220	180	52	535	100	140	ISO 228-G¼	M16	20	8	4	4	8	13
125	250	210	56	601	100	140	ISO 228-G¼	M16	22	8	4	4	6	16
150	285	240	56	698	160	180	ISO 228-G¼	M20	21	8	4	4	10	26
200	340	295	60	828	160	180	ISO 228-G¼	M20	23	8	4	4	8	32
250	395	350	68	987	200	220	ISO 228-G¼	M20	19	12	6	6	6	46
300	445	400	78	1114	200	220	ISO 228-G¼	M20	23	12	6	6	5	78
350	505	460	78	1329	250	270	ISO 228-G½	M20	20	16	8	8	4	108
400	565	515	102	1461	250	270	ISO 228-G½	M24	28	16	6	10	4	134

*Application for supply air pressure of 6 bar in troublefree media.